

MODERN VACUUMBALANCES

Th. Gast¹ and E. Robens²

¹Institut für Meß- und Regelungstechnik der Technischen Universität Berlin, D-10787 Berlin, Germany

²Institut für Anorganische und Analytische Chemie der Johannes Gutenberg-Universität, D-55099 Mainz, Germany

Abstract

Different types of vacuum balances have been developed corresponding to the various applications [1]:

– Special beam balances are applied for metrology and thermogravimetry and for the investigation of physical and chemical reactions of solid samples with the gas phase. Today, with all these balances the beam deflection is observed by an inductive or photoelectric sensor and electromagnetically restored.

– In corrosive atmospheres or under very clean conditions e.g. for investigations in ultrahigh vacuum the magnetic suspension balance should be favoured. The sample tube is separated from the balance and can be hermetically sealed from the environment. It contains only the pan with the sample connected to a permanent magnet, suspended at a stable position in the field of a controlled electromagnet. The carrying balance is electrostatically compensated.

– The spring balance is an inexpensive alternative, if a minor relative resolution can be accepted. The simple design utilizing only few materials enables measurements under very clean conditions. A quartz spring allows for investigations in corrosive atmosphere. The extension of the spring is observed optically or by means of an inductive sensor.

– Quartz resonators are used to control vacuum metallizing and other evaporating and sputtering processes. Resonator systems of any type need no gravitational field and can be applied, therefore, in space technology. The mass determination is restricted to samples which are strongly connected to the surface of the sensor.

Keywords: microbalances, vacuumbalances

Methods of weighing in vacuum

We have three possibilities to weigh in vacuo or in a controlled atmosphere:

The most-spread one is to put a balance in a vacuum vessel (Fig. 1a). It may be a beam, a spring or a resonator type balance or any other force sensor e.g. based on strain gauges, whereby the beam balance is favoured by the possibility of comparison measurements to a reference mass. It is disadvantageous that the balance system can worsen the vacuum and may be affected by corrosive reaction gases.

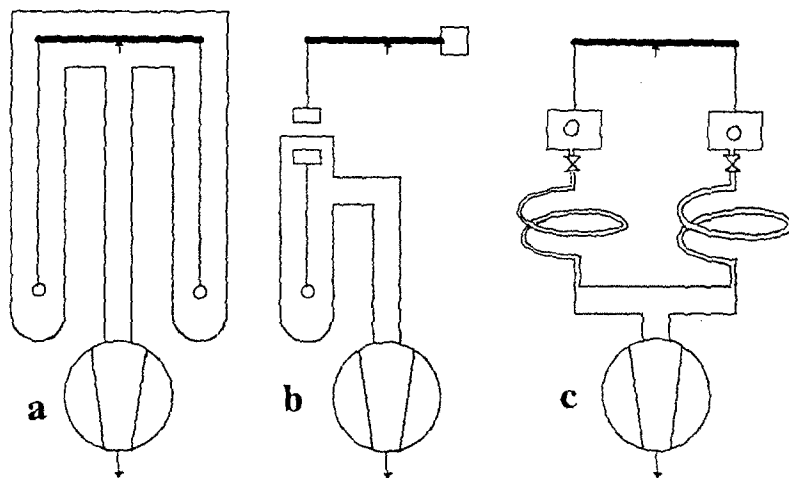

Fig. 1 Difference weighing by means of a beam balance (a); Suspension balance (b); Difference weighing of evacuated vessels (c)

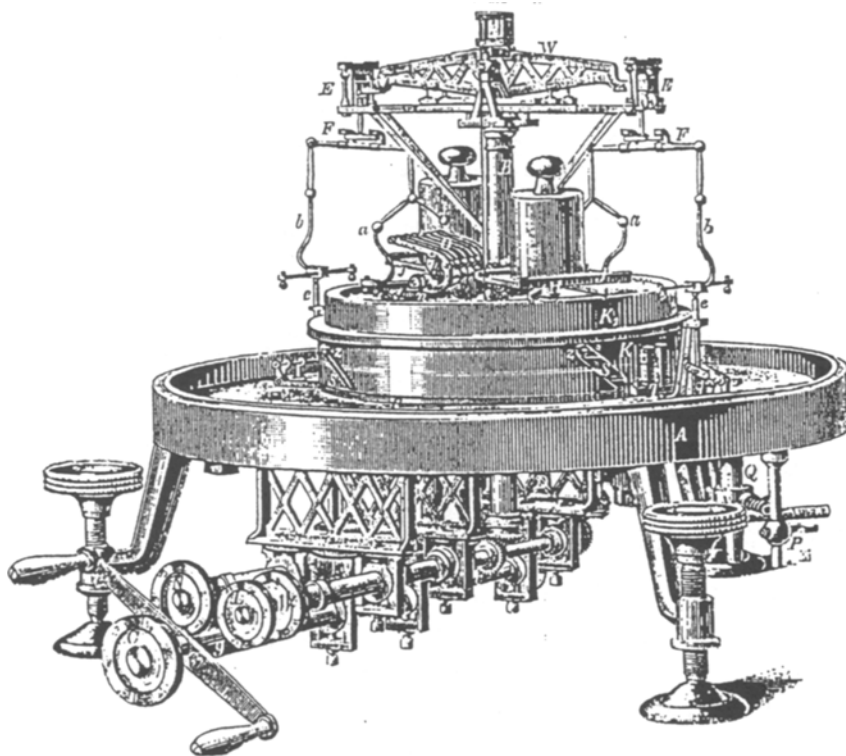

Fig. 2 Metrological comparator balance of Krusper and Nemetz of the Hungarian Bureau of Standards, Budapest

– This is avoided by the magnetic suspension balance (Fig. 1b). The sample pan is connected to a permanent magnet, which is suspended in some distance from a controlled magnet hung from the balance system and enclosed in a hermetically sealed vacuum vessel. Some part of the loading capacity is occupied by the magnets. Suspension balances are expensive because in addition to the primary balance the suspension equipment is required.

– A third procedure consists in simply placing the vacuum vessel with sample on the balance and perhaps a reference vessel at the opposite side. This method is applied for highly sensitive investigations of gas densities and of molecular mass. If, however, the reaction gas or its pressure should be variable, a connection tube is required which will exert disturbing forces on the balance. It is advantageous, that after a first calibration no change of the buoyancy influence occurs. In the following we abstain from describing such apparatus, because no special vacuum balances are used.

Vacuum macrobalances

Some thermobalances with maximum load above 100 g are suitable also in vacuum. Vacuum balances with maximum loads up to some kilograms and extremely high relative resolution are in use in particular for metrological purposes. An example is the balance of Krusper and Nemetz, used at the Hungarian Bureau of Standards until 1945. All comparators are common type equal-armed or single-sided mechanical balances, in its latest development with electrodynamic compensation in the milligram range. A characteristic feature is the alternate device for the mass prototypes within the vacuum vessel. In general, the weights are compared at ambient pressure and the vacuum vessel provides only a protection for the balance. Furthermore, load cells and strain gauges are applied in industrial processes. More about vacuum macrobalances may be found in the literature [1–3].

Vacuum microbalances

The following survey is focused on vacuum microbalances with maximum load up to about 100 g and a resolution down to the nanogram range.

Spring balances

On account of its simplicity spring balances are particularly appropriate for the use in a vacuum apparatus (Fig. 3). The few materials used enable measurements under very clean conditions. A quartz spring is suitable for investigations in corrosive atmosphere [4]. The extension of the spring is observed optically or by means of an inductive sensor. Differently from beam balances a direct

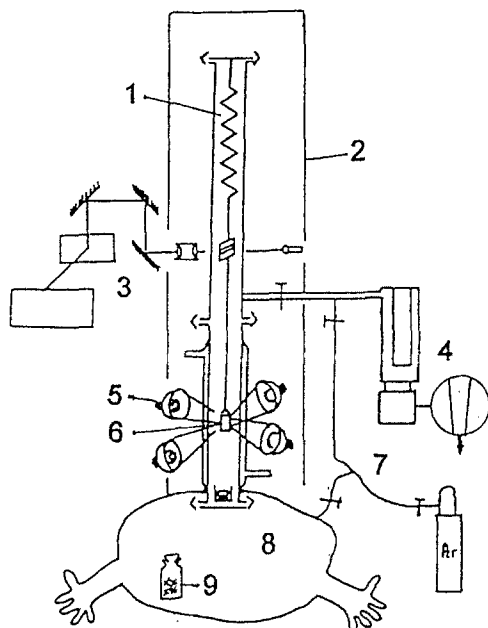

Fig. 3 Scheme of an apparatus equipped with a helical spring balance according to Gérard.
 1 - quartz spring, 2 - heat insulation, 3 - optical recording device, 4 - oil diffusion pump with cold trap, 5 - infrared heater, 6 - target, 7 - gas inlet, 8 - polyethylene bag with gloves, 9 - sample material

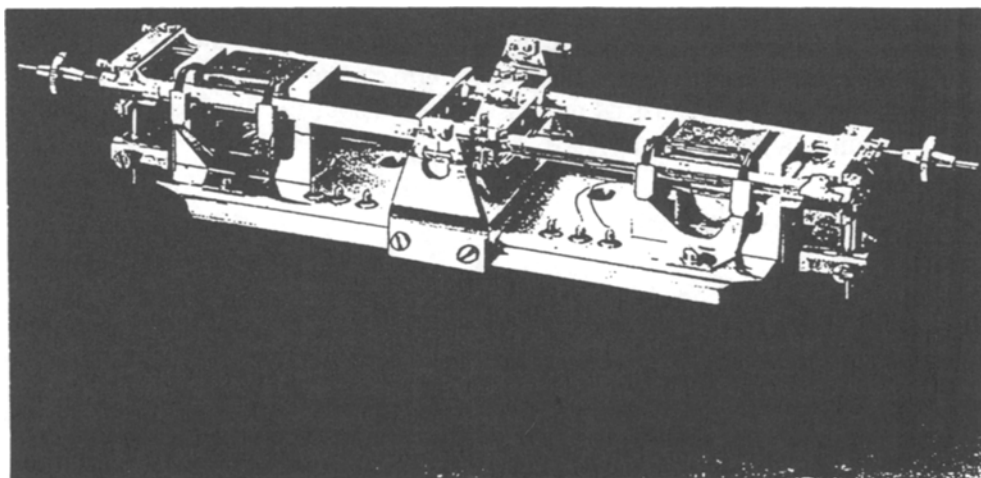

Fig. 4 Vacuum microbalances according to Gast with double quartz tube beam. Sartorius AG, Göttingen, Germany

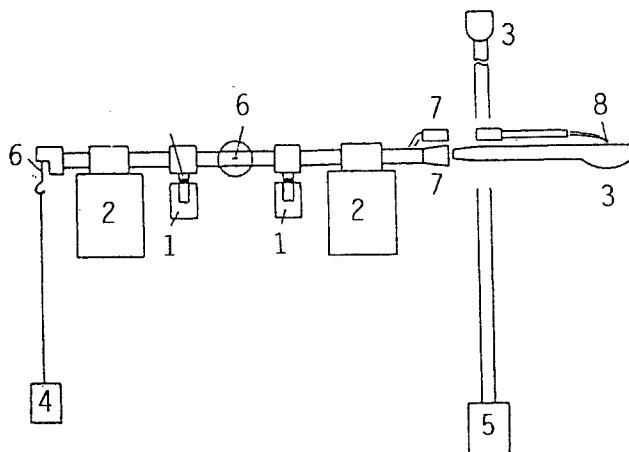

Fig. 5 Thermobalance with quartz tube beam and plug-in sample carrier. Linseis, Selb, Germany. 1 - inductive sensors, 2 - restoring plunger coil / magnet systems, 3 - sample pans, 4 - reference material, 5 - counterweight, 6 - taut bands, 7 - plug-in connections, 8 - thermocouple

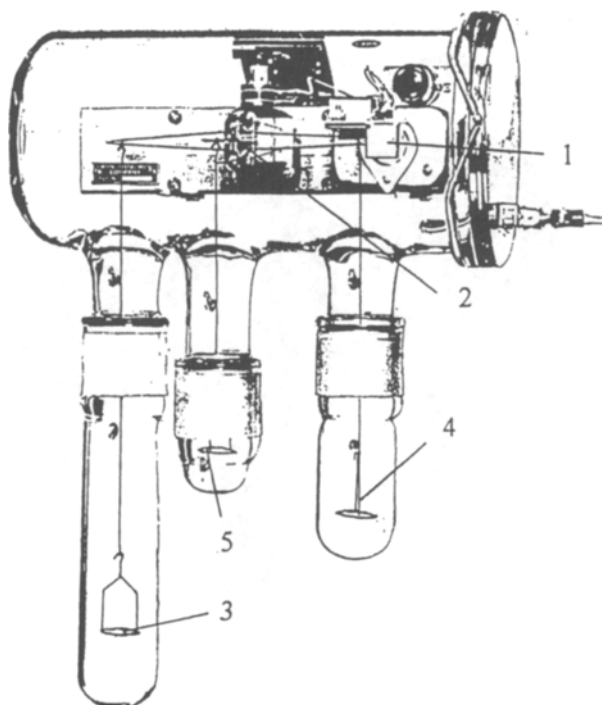

Fig. 6 Vacuum balance with wire beam. Cahn Instruments, Cerritos CA, USA. 1 - photocell, 2 - force compensating coil, 3 - sample pan for high sensitivity, 4 - reference material, 5 - sample pan for high load

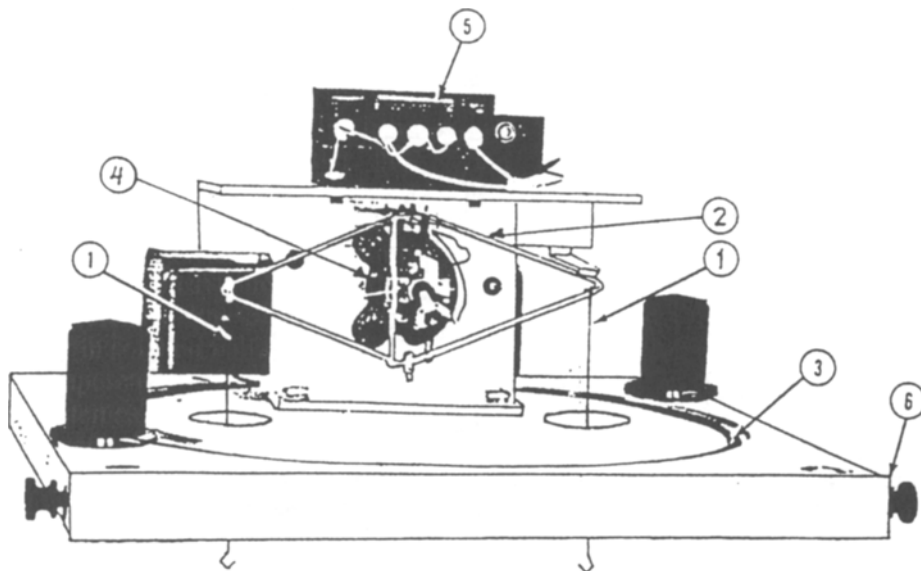

Fig. 7 Vacuum balance with rhombus-shaped wire beam. Perkin-Elmer, Norwalk, Conn., USA. 1 - hangdown wires, 2 - rhombus-shaped beam, 3 - groove with O-ring, 4 - position sensor and force compensating moving coil, 5 - connector

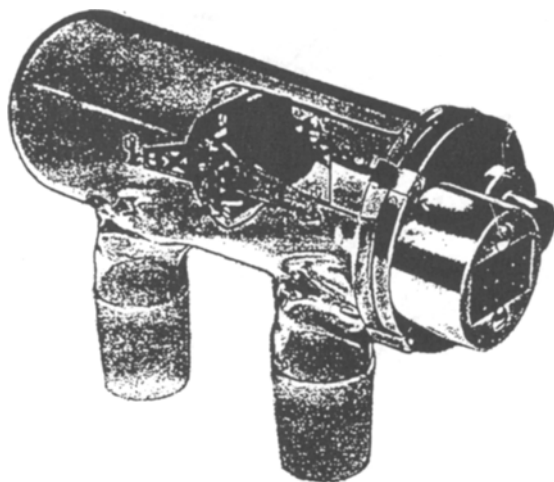

Fig. 8 Vacuum balance with framework beam CI Electronics, Salisbury, Wilts., Great Britain

measurement of the force of the load in the gravitational field is performed and not a difference measurement with reference to a counterweight and buoyancy cannot be cancelled. Thus, spring balances can never reach as low values of relative resolution [5] as beam balances. As far as we know, no spring balances

for the vacuum are manufactured. Only springs of quartz or metal are offered for that purpose, but the observation equipment has to be added. On principal, spring balances can be operated by means of electronic control in the same way as is practiced with beam balances.

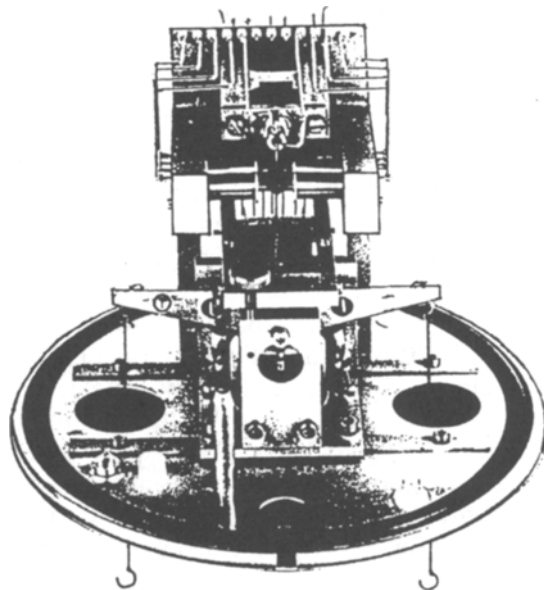

Fig. 9 Vacuum balance with short, punched beam. SETARAM, Caluire, France

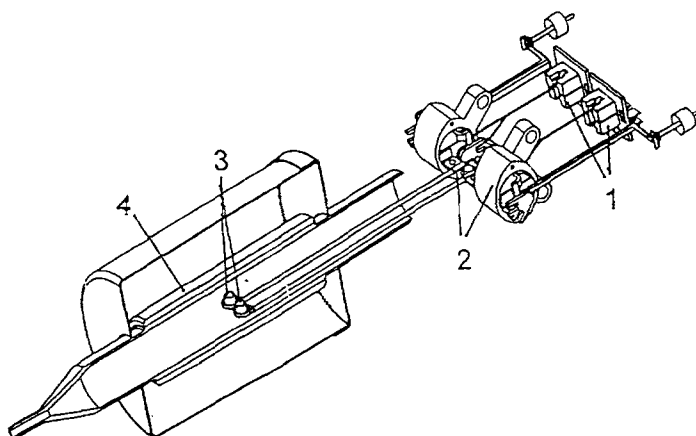

Fig. 10 Thermobalance with two measuring systems in parallel. TA Instruments, Newcastle, Conn., USA. 1 - photocells, 2 - force compensating coils, 3 - sample and reference material, 4 - oven

Compensating beam balances

Today's vacuum balances are special type beam balances, the beam suspended by a horizontally stretched taut band. The beam deflection is observed by an inductive or photoelectric sensor and is electro-dynamically restored. Three subassemblies may be distinguished: the balance itself, the controller and the output unit. Whereas the mechanical design, the compensating magnet/coil system and the deflection sensors did not change in principle within the last decades, improvements were made of the controllers as a result of the development in electronics. The most impressive changes concern the data output. Digital records allow online data processing, comprising correction and transformation of results and display in real time. In the following we will nevertheless present examples for the balance system, because its design and finish are decisive for the suitability in various applications rather than the comfort in the output.

The beam of the Gast balance, as produced until recently by Sartorius, is a quartz tube, for higher loads two parallel tubes form a ladder (Fig. 4). The surface of the tubes is covered with silver to allow an electric connection to the sample pans. For loads up to two grams as bearings at each end two spherical sapphire cups are pivoted on diamond pins. For loads of some ten grams the sample pans are suspended via two short metal bands at each side. A thermobalance with quartz tube beam and plug connection is produced by Linseis (Fig. 5). This enables the extension of the beam and an optional top-position of the sam-

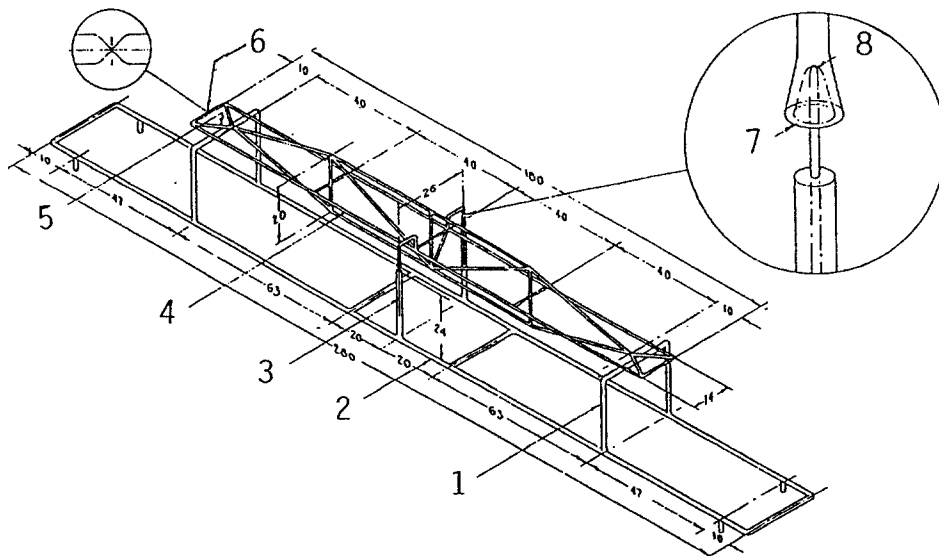

Fig. 11 Beam of Czanderna's balance. 1 - beam arrest, 2 - frame, 3 - tungsten wire, 4 - three dimensional trussed beam, 5 - yoke, 6 - suspension fibre support, 7 - quartz cup, 8 - tungsten point

ple but restricts the relative. The 1 g Cahn balance (Fig. 6) is equipped with a metal wire beam. The deflection is detected by means of a photocell. For high loads Cahn uses a metal beam and a coil system as a position sensor. The beam of the Perkin Elmer balance (Fig. 7) is a rhombus-shaped wire. The balance of CI Electronics (Fig. 8) is designed as a framework. The triangular-shaped massive metal beam of Setaram (Fig. 9) is punched. It is only 6 cm in length and allows for arranging the sample and a reference sample in a common thermostat tube. The magnet/coil system is rather large. A thermobalance with two single-armed systems in parallel (Fig. 10) is offered by TA Instruments. Sample and reference sample can be treated in a laterally arranged oven. Although out of production, we recall the Czanderna balance, which might have had the best relation of detection limit to maximum load of all vacuum microbalances. The beam consists of a three-dimensional framework of quartz wires (Fig. 11). The bearings consist of quartz cups placed on tungsten tips.

Oscillators

Resonator systems for the measurement of mass changes are realized as oscillating strings, bands and in the form of quartz resonators, which achieve an

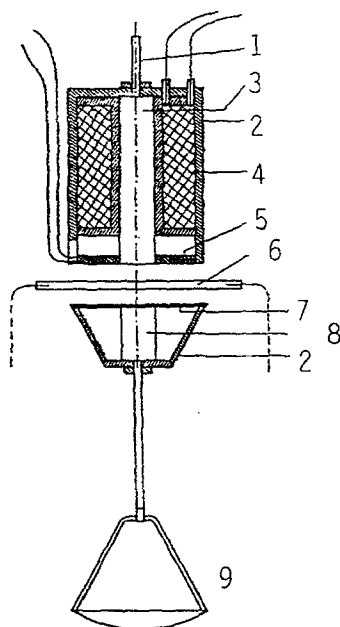

Fig. 12 Scheme of the suspension device. 1 - suspension of the supporting magnet, 2 - iron casing, 3 - supporting bar magnet, 4 - control winding, 5 - indicator winding, 6 - glass window, 7 - copper disc (eddy current sensor), 8 - suspended permanent magnet, 9 - sample pan, 10 - recipient, 11 - fulcrum, 12 - balance beam, 13 - electromagnetic position sensor and actuator, 14 - thermostatted casing

extremely high sensitivity. The measuring system is very small and clean and can even be baked. So it is very suitable in vacuo. Quartz resonators are used to control vacuum metallizing and other evaporation and sputtering processes and to record contamination. Because resonator type balances need no gravitational field they can be applied in space. The mass determination is restricted to samples which are strongly connected to the surface of the sensor. As far we know only one quartz resonator for mass determination is on the market but a great variety of layer thickness monitors.

Magnetic suspension balances

There are several ways of establishing and controlling free suspension. Most frequent practical application was obtained by the controlled ferromagnetic attraction (Fig. 12): An upper bar magnet suspended from the beam of an electromagnetic balance carries a lower magnet with a pan. A nonmagnetic, preferably dielectric, wall between the attracting poles separates the reaction

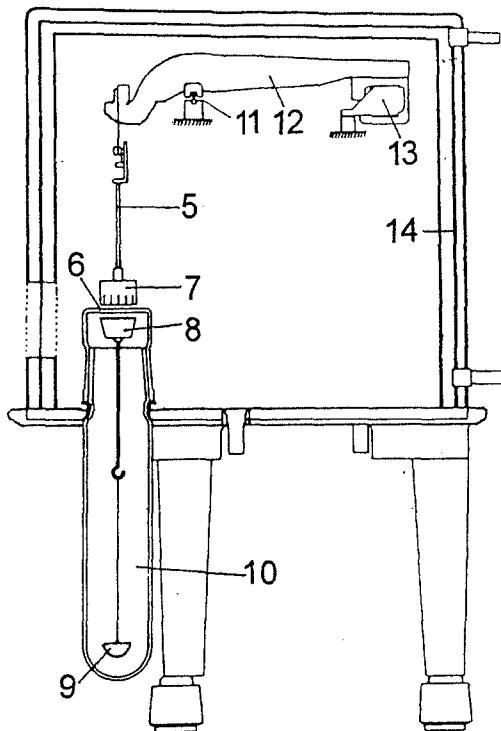

Fig. 13 Scheme of a magnetic suspension balance. 1 - suspension of the supporting magnet, 2 - iron casing, 3 - supporting bar magnet, 4 - control winding, 5 - indicator winding, 6 - glass window, 7 - copper disc (eddy current sensor), 8 - suspended permanent magnet, 9 - sample pan, 10 - recipient, 11 - fulcrum, 12 - balance beam, 13 - electromagnetic position sensor and actuator, 14 - thermostatted casing

chamber from the balance. The distance of the magnets is measured by an eddy current sensor while a superimposed control loop keeps the controlling power at a minimum. An example gives the Gast suspension balance (Fig. 13) which had been built by Sartorius [6]. The suspension balance after Wagner, Kleinrahm and Lösch [7], produced by Rubotherm (Fig. 14), is based on the same principle, but instead of pole distance, the position of the lower magnet is measured.

Hermetically sheltered from the atmosphere and the measuring system, the sample can be held under extremely clean conditions e.g. in ultrahigh vacuum or treated with corrosive gases under variable temperature and pressure. Any contamination of the measuring system by deleterious sample components is excluded. Thus, by equipment with a suspension system, the applicability of a balance is remarkably extended.

In the development of electromagnetic balances, progress in sensor technology and permanent magnetic materials, electrical components and circuitry have extended the range of electromagnetic compensation from a small fraction of the measurement range to the full capacity of the balance used. The balance

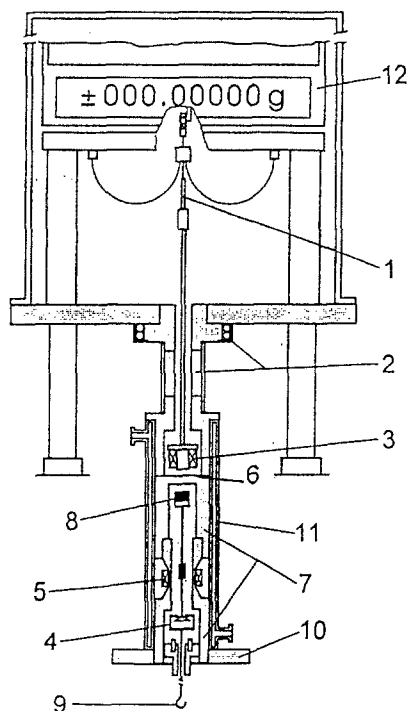

Fig. 14 Rubotherm magnetic suspension balance. 1 - suspension of the supporting magnet, 2 - cooler, 3 - supporting electromagnet, 4 - load decoupling, 5 - position sensor, 6 - copper beryllium or copper chrome zirconium window, 7 - coupling housing, 8 - suspended permanent magnet, 9 - sample hook, 10 - recipient flange, 11 - electromagnetic balance, 12 - thermostatted casing

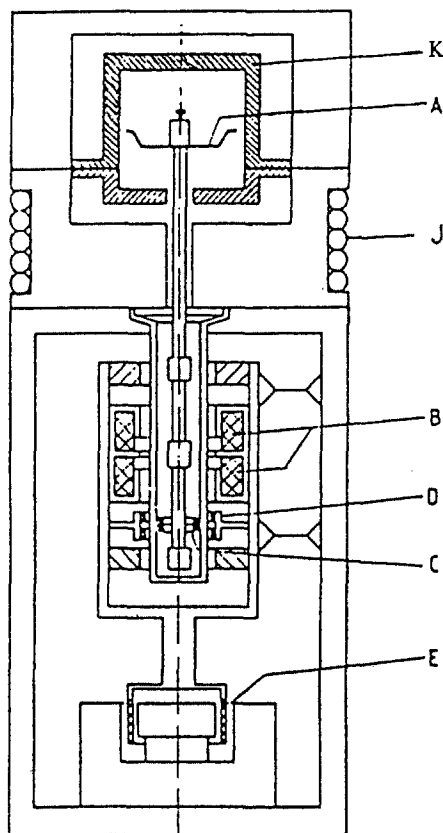

Fig. 15 High pressure top-load suspension. A - pan, B - control coils, C - metal ring, D - sensor coils, E - actuator coil, J - cooling spiral, K - oven

beam could be replaced by a system of parallel levers, which guide the balance pan in a vertical path of deflection. In prototypes any mechanical guidance could be omitted and replaced by artificially stabilized magnetic attraction or repulsion which can also be combined. A variety of balances from microgram to the kilogram range with the sample below the measuring system as well as for top loaders (Fig. 15) were realized [8].

The precision of the distance measurement could be considerably improved by the application of a phase locked loop. With the aid of an improved eddy current sensor, a frequency signal is obtained, which allows weighing without external balance with an uncertainty of $1 \cdot 10^{-5}$. Distance control is also possible by extracting the velocity signal, which is induced in the control winding by vertical motion of the magnet, from the superimposed regulating voltage [9]. Further improvement allows the coupling device to be used in addition to transmit data for other parameters, like the sample temperature [10]. Later development concerned the arrangement of the distance control from outside the balance [11,

12]. Using a Hall probe as a distance sensor, a partition of poorly conducting material between the suspension magnets can be avoided. Thus, the sample space can be enclosed in a high pressure autoclave.

References

- 1 Th. Gast, T. Brokate, E. Robens: "Vakuummägung". In: M. Gläser, M. Kochsiek (eds.): Massebestimmung. VCH-Verlag, Weinheim 1995.
- 2 H. R. Jenemann, E. Robens: "History of the vacuum macrobalance" In: J.U. Keller, E. Robens (eds.): Microbalance Techniques. Multiscience Publishing, Brentwood 1994, p. 13–23.
- 3 B. Haltmeier, D. Maillard: "The latest microweighing and vacuum technology applied to the search of the fifth force" In: J. U. Keller, E. Robens (eds.): Microbalance Techniques. Multiscience Publishing, Brentwood 1994, p. 268–269.
- 4 N. Gérard: Thermogravimetric investigation of the decomposition kinetics of a gaseous aluminum hydride compound. In: J.U. Keller, E. Robens (eds.): Microbalance Techniques. Multiscience Publishing, Brentwood 1994, p. 81–84.
- 5 E. Robens: The characterization of the capability of a balance. This volume.
- 6 Th. Gast, "Microweighing in vacuo with a magnetic suspension balance". In: K.H. Behrndt (ed.): Vacuum Microbalance Techniques, Vol. 3, Plenum Press 1963, p. 45–54.
- 7 H. W. Lösch, J.V. Vietinghoff, W. Wagner and R. Kleinrahm: Microbalance Techniques (1994) p 79.
- 8 Th. Gast, A. Mirahmadi and F. A. Wagner, Acta Imeko, (1979) 599.
- 9 Th. Gast and G. Lutce, "A directly weighing suspension balance with frequency variant output". In: H. Wieringa (ed.): Mechanical Problems in Measuring Force and Mass, M. Nijhoff; Dordrecht 1986.
- 10 Th. Gast, H. Jakobs and G. Lutce, Thermochemica Acta, 82 (1984) 1.
- 11 Th. Gast and W. Pahlke: J. Thermal Anal., 37 (1991) 1933.
- 12 W. Brenner, W. Pahlke, E. Robens, K.K. Unger and Th. Gast: Microbalance Techniques, (1994) 73.